

FEATURES

Filterless Class-D amplifier with built-in output stage
1.4 W into 8 Ω at 5.0 V supply with less than 1% THD
85% efficiency at 5.0 V, 1.4 W into 8 Ω speaker
Better than 98 dB SNR (signal-to-noise ratio)
Single-supply operation from 2.5 V to 5.0 V
20 nA ultralow shutdown current
Short-circuit and thermal protection
Available in 16-lead, 3 mm \times 3 mm LFCSP
Pop-and-click suppression
Built-in resistors reduce board component count
Fixed and user-adjustable gain configurations

APPLICATIONS

Mobile phones
MP3 players
Portable gaming
Portable electronics
Educational toys

GENERAL DESCRIPTION

The SSM2302 is a fully integrated, high efficiency, Class-D stereo audio amplifier. It is designed to maximize performance for mobile phone applications. The application circuit requires a minimum of external components and operates from a single 2.5 V to 5.0 V supply. It is capable of delivering 1.4 W of continuous output power with less than 1% THD + N driving an 8 Ω load from a 5.0 V supply.

The SSM2302 features a high efficiency, low noise modulation scheme. It operates with 85% efficiency at 1.4 W into 8 Ω from a

5.0 V supply and has a signal-to-noise ratio (SNR) that is better than 98 dB. PDM modulation is used to provide lower EMI-radiated emissions compared with other Class-D architectures.

The SSM2302 has a micropower shutdown mode with a typical shutdown current of 20 nA. Shutdown is enabled by applying a logic low to the SD pin.

The architecture of the device allows it to achieve a very low level of pop and click. This minimizes voltage glitches at the output during turn-on and turn-off, thus reducing audible noise on activation and deactivation.

The fully differential input of the SSM2302 provides excellent rejection of common-mode noise on the input. Input coupling capacitors can be omitted if the dc input common-mode voltage is approximately $V_{DD}/2$.

The SSM2302 also has excellent rejection of power supply noise, including noise caused by GSM transmission bursts and RF rectification. PSRR is typically 63 dB at 217 Hz.

The gain can be set to 6 dB or 12 dB utilizing the gain control select pin connected respectively to ground or V_{DD} . Gain can also be adjusted externally by using an external resistor.

The SSM2302 is specified over the commercial temperature range (-40°C to $+85^{\circ}\text{C}$). It has built-in thermal shutdown and output short-circuit protection. It is available in a 16-lead, 3 mm \times 3 mm lead-frame chip scale package (LFCSP).

FUNCTIONAL BLOCK DIAGRAM

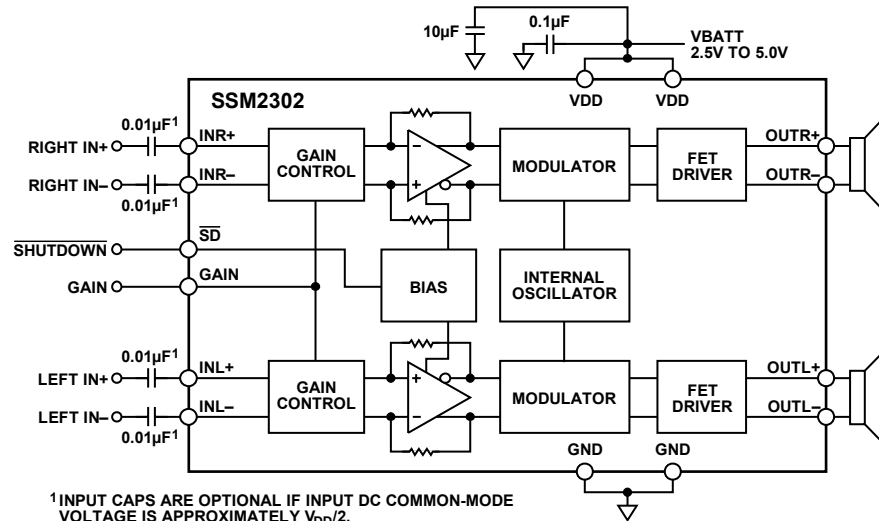

Figure 1.

Rev. 0

Information furnished by Analog Devices is believed to be accurate and reliable. However, no responsibility is assumed by Analog Devices for its use, nor for any infringements of patents or other rights of third parties that may result from its use. Specifications subject to change without notice. No license is granted by implication or otherwise under any patent or patent rights of Analog Devices. Trademarks and registered trademarks are the property of their respective owners.

TABLE OF CONTENTS

| | | | |
|--|----|--|----|
| Features | 1 | Pop-and-Click Suppression | 12 |
| Applications..... | 1 | EMI Noise..... | 12 |
| General Description | 1 | Layout | 13 |
| Functional Block Diagram | 1 | Input Capacitor Selection..... | 13 |
| Revision History | 2 | Proper Power Supply Decoupling | 13 |
| Specifications..... | 3 | Evaluation Board Information..... | 14 |
| Absolute Maximum Ratings..... | 4 | Introduction | 14 |
| Thermal Resistance | 4 | Operation | 14 |
| ESD Caution..... | 4 | SSM2302 Application Board Schematic..... | 15 |
| Pin Configuration and Function Descriptions..... | 5 | SSM2302 Stereo Class-D Amplifier Evaluation Module Component List | 16 |
| Typical Performance Characteristics | 6 | SSM2302 Application Board Layout..... | 17 |
| Typical Application Circuits..... | 9 | Outline Dimensions | 18 |
| Application Notes | 12 | Ordering Guide | 18 |
| Overview..... | 12 | | |
| Gain Selection | 12 | | |

REVISION HISTORY

6/06—Revision 0: Initial Version

SPECIFICATIONS

$V_{DD} = 5.0\text{ V}$, $T_A = 25^\circ\text{C}$, $R_L = 8\ \Omega$, unless otherwise noted

Table 1.

| Parameter | Symbol | Conditions | Min | Typ | Max | Unit |
|------------------------------------|--------------|---|-----|-------|--------------|---------------|
| DEVICE CHARACTERISTICS | | | | | | |
| Output Power | P_O | $R_L = 8\ \Omega$, THD = 1%, $f = 1\ \text{kHz}$, 20 kHz BW, $V_{DD} = 5.0\text{ V}$ | | 1.4 | | W |
| | | $R_L = 8\ \Omega$, THD = 1%, $f = 1\ \text{kHz}$, 20 kHz BW, $V_{DD} = 3.6\text{ V}$ | | 0.615 | | W |
| | | $R_L = 8\ \Omega$, THD = 1%, $f = 1\ \text{kHz}$, 20 kHz BW, $V_{DD} = 2.5\text{ V}$ | | 0.275 | | W |
| | | $R_L = 8\ \Omega$, THD = 10%, $f = 1\ \text{kHz}$, 20 kHz BW, $V_{DD} = 5.0\text{ V}$ | | 1.53 | | W |
| | | $R_L = 8\ \Omega$, THD = 10%, $f = 1\ \text{kHz}$, 20 kHz BW, $V_{DD} = 3.6\text{ V}$ | | 0.77 | | W |
| | | $R_L = 8\ \Omega$, THD = 10%, $f = 1\ \text{kHz}$, 20 kHz BW, $V_{DD} = 2.5\text{ V}$ | | 0.35 | | W |
| Efficiency | η | $P_{OUT} = 1.4\text{ W}$, $8\ \Omega$, $V_{DD} = 5.0\text{ V}$ | | 85 | | % |
| Total Harmonic Distortion + Noise | THD + N | $P_O = 1\text{ W}$ into $8\ \Omega$ each channel, $f = 1\ \text{kHz}$, $V_{DD} = 5.0\text{ V}$ | | 0.1 | | % |
| | | $P_O = 0.5\text{ W}$ into $8\ \Omega$ each channel, $f = 1\ \text{kHz}$, $V_{DD} = 3.6\text{ V}$ | | 0.04 | | % |
| Input Common-Mode Voltage Range | V_{CM} | | 1.0 | | $V_{DD} - 1$ | V |
| Common-Mode Rejection Ratio | $CMRR_{GSM}$ | $V_{CM} = 2.5\text{ V} \pm 100\text{ mV}$ at 217 Hz | | 55 | | dB |
| Channel Separation | X_{TALK} | $P_O = 100\text{ mW}$, $f = 1\ \text{kHz}$ | | 98 | | dB |
| Average Switching Frequency | f_{SW} | | | 1.8 | | MHz |
| Differential Output Offset Voltage | V_{OOS} | $G = 6\ \text{dB}$; $G = 12\ \text{dB}$ | | 2.0 | | mV |
| POWER SUPPLY | | | | | | |
| Supply Voltage Range | V_{DD} | Guaranteed from PSRR test | 2.5 | | 5.0 | V |
| Power Supply Rejection Ratio | PSRR | $V_{DD} = 2.5\text{ V}$ to 5.0 V , 50 Hz, input floating/ground | 70 | 85 | | dB |
| | $PSRR_{GSM}$ | $V_{RIPPLE} = 100\text{ mV}$ at 217 Hz, inputs ac GND, $C_{IN} = 0.01\ \mu\text{F}$, input referred | | 63 | | dB |
| Supply Current | I_{SY} | $V_{IN} = 0\text{ V}$, no load, $V_{DD} = 5.0\text{ V}$ | | 8.0 | | mA |
| | | $V_{IN} = 0\text{ V}$, no load, $V_{DD} = 3.6\text{ V}$ | | 6.6 | | mA |
| | | $V_{IN} = 0\text{ V}$, no load, $V_{DD} = 2.5\text{ V}$ | | 5.3 | | mA |
| Shutdown Current | I_{SD} | $\overline{SD} = \text{GND}$ | | 20 | | nA |
| GAIN CONTROL | | | | | | |
| Closed-Loop Gain | A_{v0} | GAIN pin = 0 V | | 6 | | dB |
| | A_{v1} | GAIN pin = V_{DD} | | 12 | | dB |
| Differential Input Impedance | Z_{IN} | $\overline{SD} = V_{DD}$ | | 150 | | K Ω |
| | | $\overline{SD} = \text{GND}$ | | 210 | | K Ω |
| SHUTDOWN CONTROL | | | | | | |
| Input Voltage High | V_{IH} | $I_{SY} \geq 1\ \text{mA}$ | | 1.2 | | V |
| Input Voltage Low | V_{IL} | $I_{SY} \leq 300\ \text{nA}$ | | 0.5 | | V |
| Turn-On Time | t_{WU} | \overline{SD} rising edge from GND to V_{DD} | | 30 | | ms |
| Turn-Off Time | t_{SD} | \overline{SD} falling edge from V_{DD} to GND | | 5 | | μs |
| Output Impedance | Z_{OUT} | $\overline{SD} = \text{GND}$ | | >100 | | K Ω |
| NOISE PERFORMANCE | | | | | | |
| Output Voltage Noise | e_n | $V_{DD} = 2.5\text{ V}$ to 5.0 V , $f = 20\ \text{Hz}$ to $20\ \text{kHz}$, inputs are ac grounded, sine wave, $A_v = 6\ \text{dB}$, A weighting | | 35 | | μV |
| Signal-to-Noise Ratio | SNR | $P_{OUT} = 1.4\text{ W}$, $R_L = 8\ \Omega$ | | 98 | | dB |

SSM2302

ABSOLUTE MAXIMUM RATINGS

Absolute maximum ratings apply at 25°C, unless otherwise noted.

Table 2.

| Parameter | Rating |
|---|-----------------|
| Supply Voltage | 6 V |
| Input Voltage | V _{DD} |
| Common-Mode Input Voltage | V _{DD} |
| Storage Temperature Range | -65°C to +150°C |
| Operating Temperature Range | -40°C to +85°C |
| Junction Temperature Range | -65°C to +165°C |
| Lead Temperature Range (Soldering, 60 sec) | 300°C |

Stresses above those listed under Absolute Maximum Ratings may cause permanent damage to the device. This is a stress rating only; functional operation of the device at these or any other conditions above those indicated in the operational section of this specification is not implied. Exposure to absolute maximum rating conditions for extended periods may affect device reliability.

THERMAL RESISTANCE

θ_{JA} is specified for the worst-case conditions, that is, a device soldered in a circuit board for surface-mount packages.

Table 3. Thermal Resistance

| Package Type | θ_{JA} | θ_{JC} | Unit |
|----------------------------|---------------|---------------|------|
| 16-lead, 3 mm × 3 mm LFCSP | 44 | 31.5 | °C/W |

ESD CAUTION

ESD (electrostatic discharge) sensitive device. Electrostatic charges as high as 4000 V readily accumulate on the human body and test equipment and can discharge without detection. Although this product features proprietary ESD protection circuitry, permanent damage may occur on devices subjected to high energy electrostatic discharges. Therefore, proper ESD precautions are recommended to avoid performance degradation or loss of functionality.



PIN CONFIGURATION AND FUNCTION DESCRIPTIONS

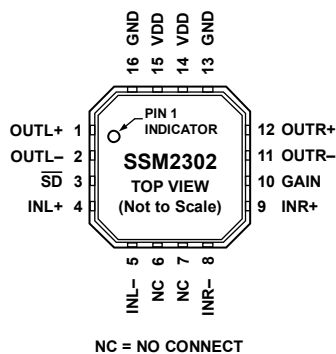

Figure 2. SSM2302 LFCSP Pin Configuration

Table 4. Pin Function Descriptions

| Pin No. | Mnemonic | Description |
|---------|-----------------|---|
| 1 | OUTL+ | Inverting Output for Left Channel. |
| 2 | OUTL- | Noninverting Output for Left Channel. |
| 3 | \overline{SD} | Shutdown Input. Active low digital input. |
| 4 | INL+ | Noninverting Input for Left Channel. |
| 5 | INL- | Inverting Input for Left Channel. |
| 6 | NC | No Connect. |
| 7 | NC | No Connect. |
| 8 | INR- | Inverting Input for Right Channel. |
| 9 | INR+ | Noninverting Input for Right Channel. |
| 10 | GAIN | Gain Selection. Digital input. |
| 11 | OTR- | Noninverting Output for Right Channel. |
| 12 | OTR+ | Inverting Output for Right Channel. |
| 13 | GND | Ground for Output Amplifiers. |
| 14 | VDD | Power Supply for Output Amplifiers. |
| 15 | VDD | Power Supply for Output Amplifiers. |
| 16 | GND | Ground for Output Amplifiers. |

TYPICAL PERFORMANCE CHARACTERISTICS

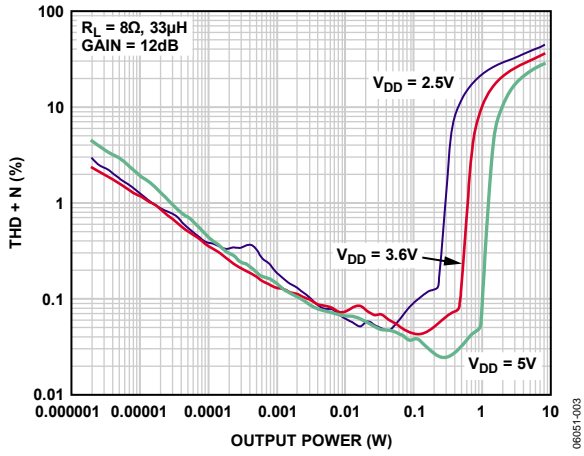

Figure 3. THD + N vs. Output Power into 8Ω, Av = 12 dB

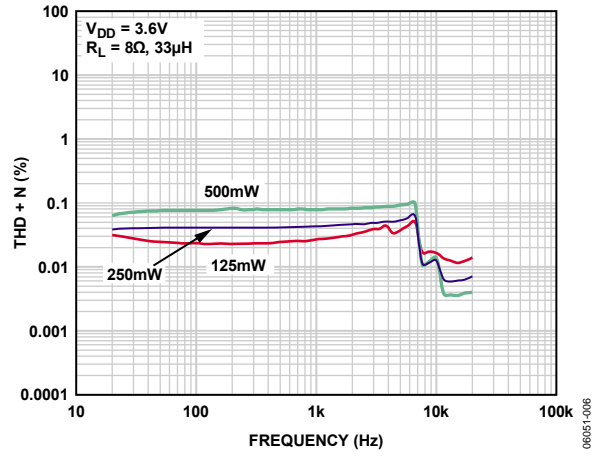

Figure 6. THD + N vs. Frequency, VDD = 3.6 V

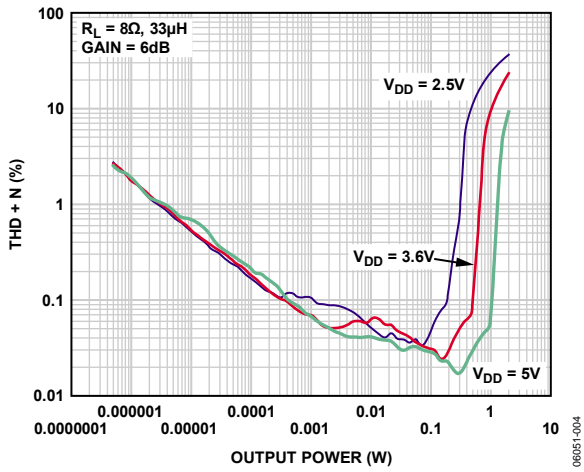

Figure 4. THD + N vs. Output Power into 8Ω, Av = 6 dB

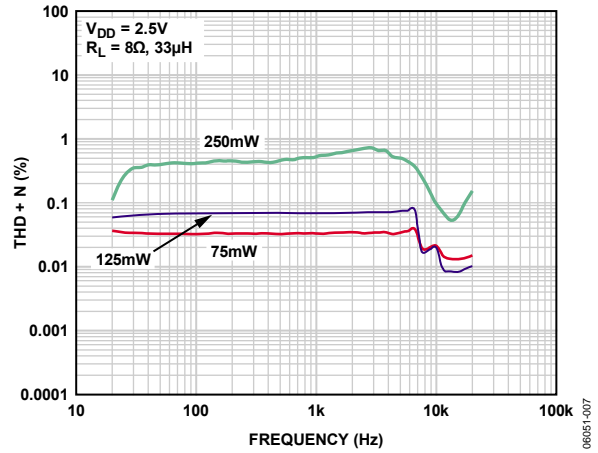

Figure 7. THD + N vs. Frequency, VDD = 2.5 V

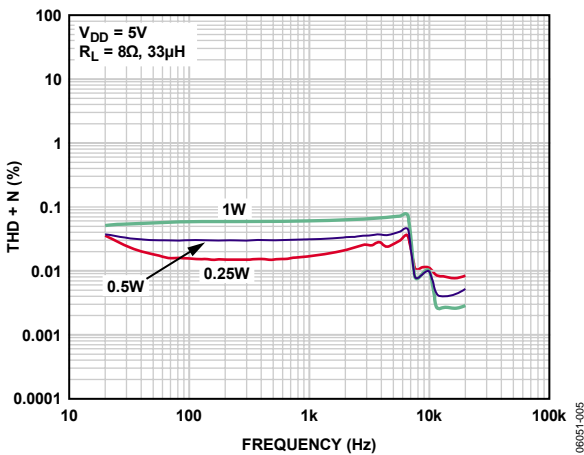

Figure 5. THD + N vs. Frequency, VDD = 5.0 V

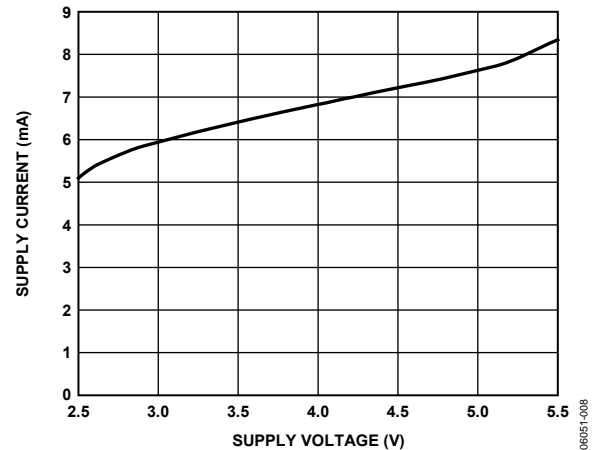

Figure 8. Supply Current vs. Supply Voltage, No Load

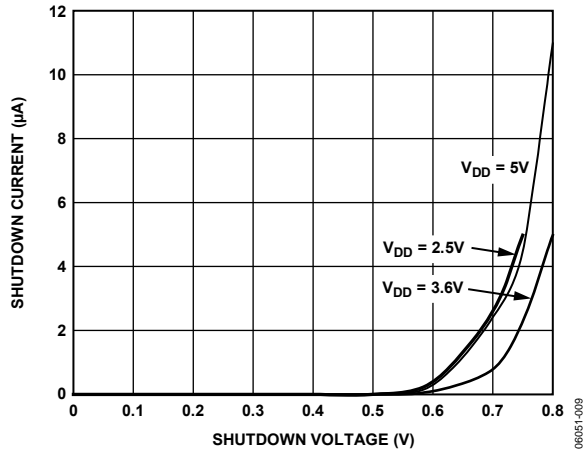

Figure 9. Supply Current vs. Shutdown Voltage

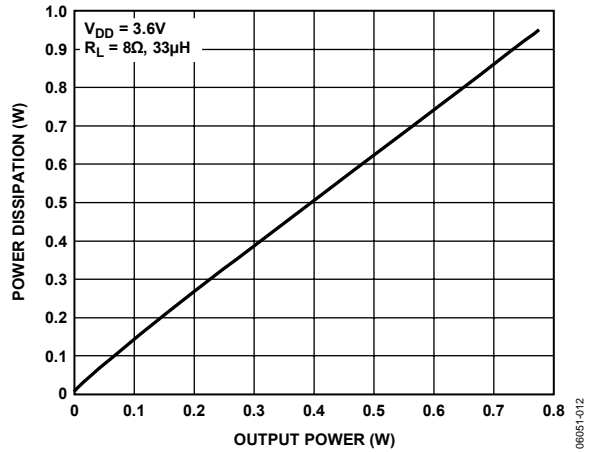

Figure 12. Power Dissipation vs. Output Power at $V_{DD} = 3.6V$

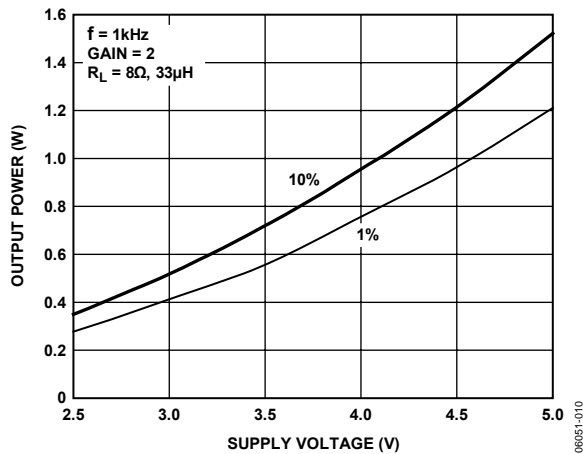

Figure 10. Maximum Output Power vs. Supply Voltage

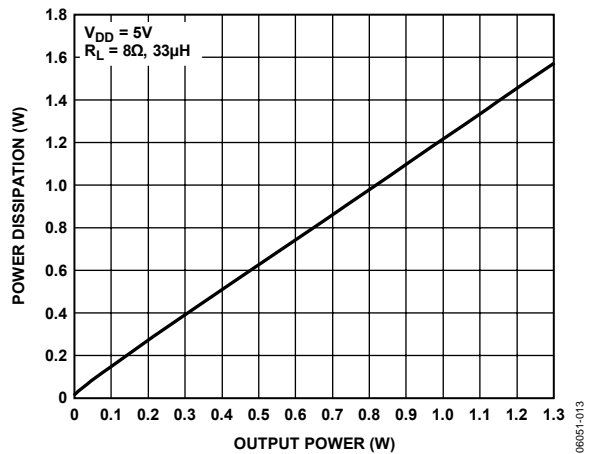

Figure 13. Power Dissipation vs. Output Power at $V_{DD} = 5.0V$

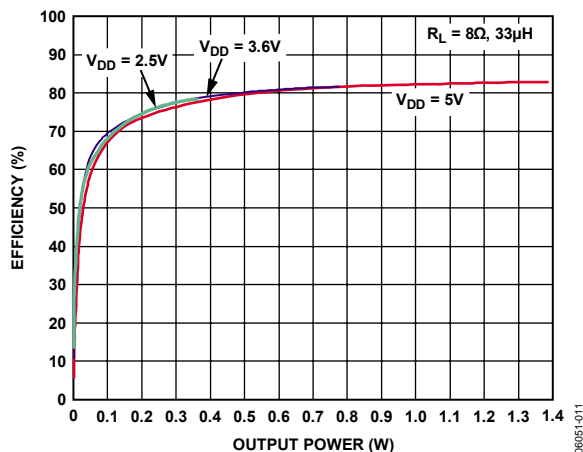

Figure 11. Efficiency vs. Output Power into 8Ω

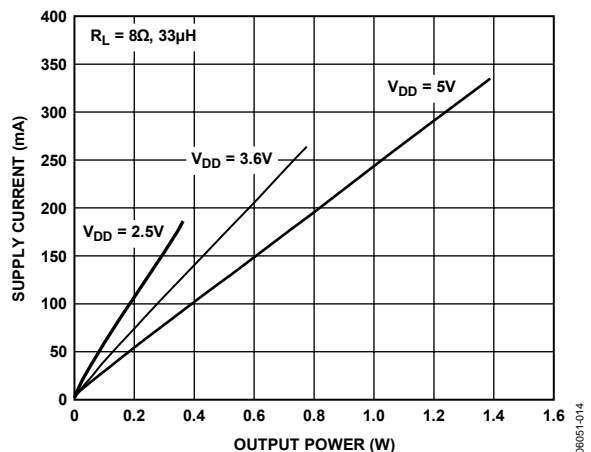

Figure 14. Output Power vs. Supply Current, One Channel

SSM2302

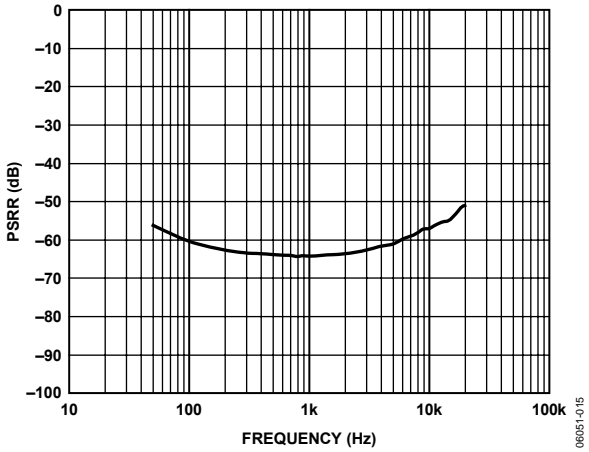

Figure 15. Power Supply Rejection Ratio vs. Frequency

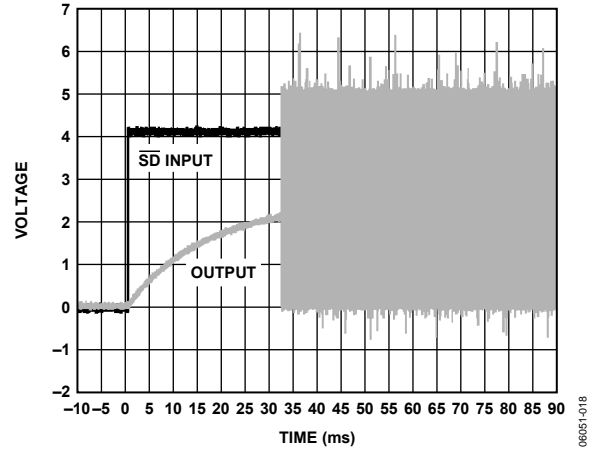

Figure 18. Turn-On Response

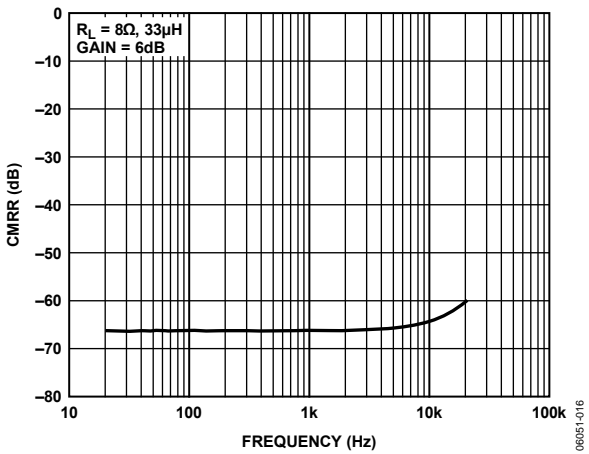

Figure 16. Common-Mode Rejection Ratio vs. Frequency

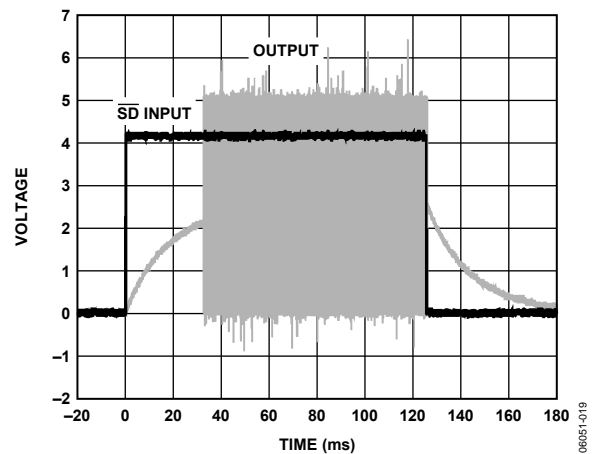

Figure 19. Turn-Off Response

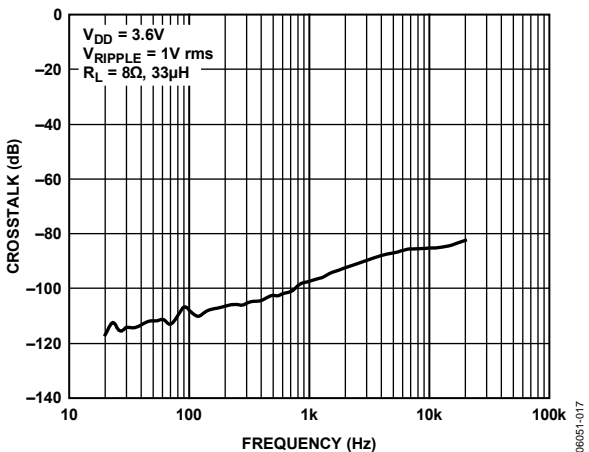

Figure 17. Crosstalk vs. Frequency

TYPICAL APPLICATION CIRCUITS

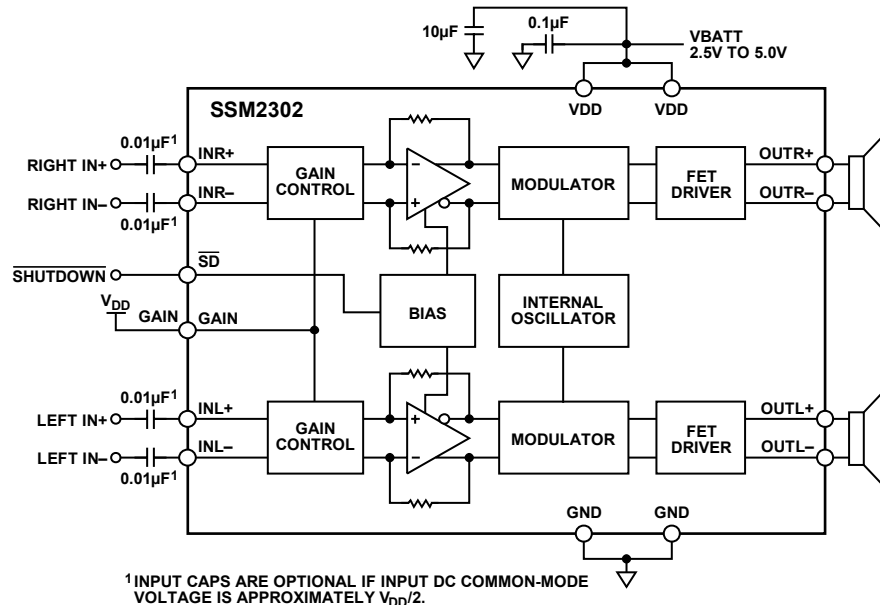

Figure 20. Stereo Differential Input Configuration, Gain = 12 dB

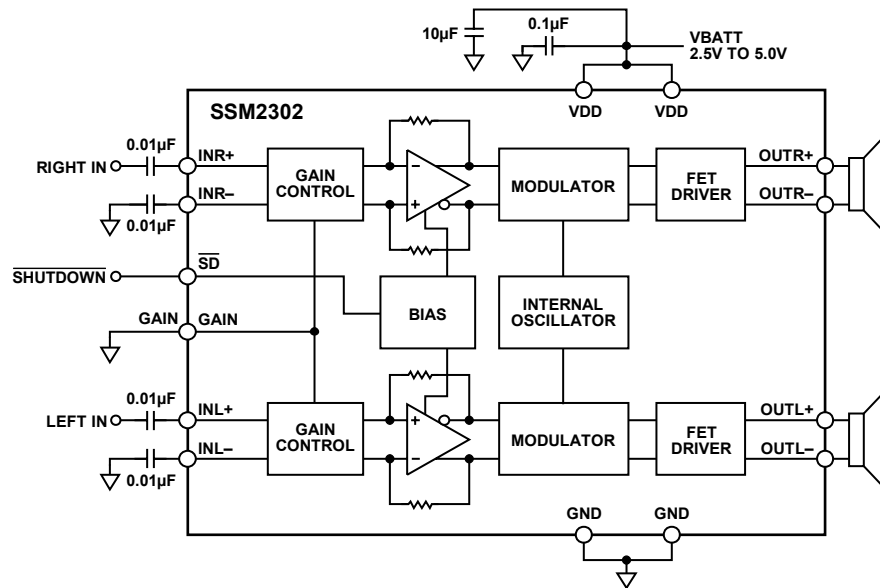
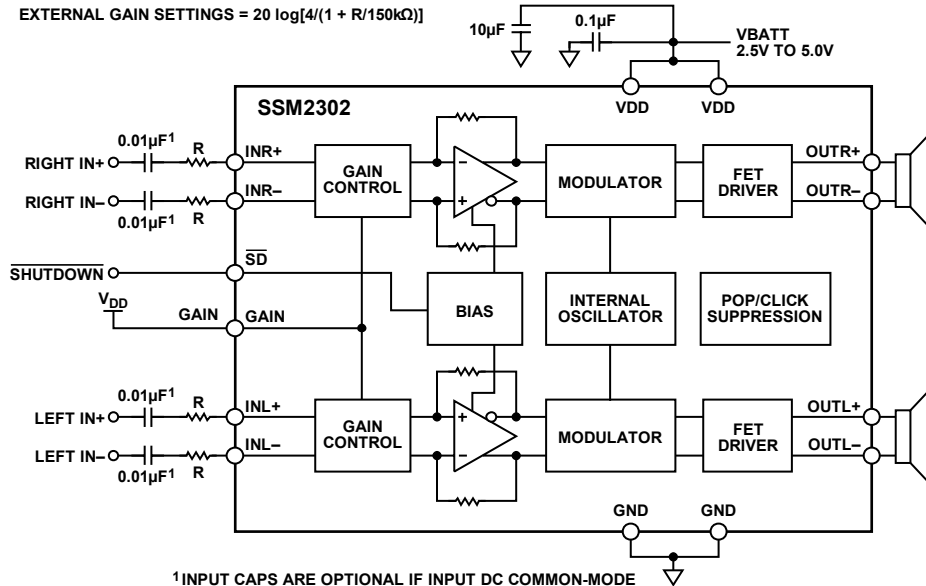

Figure 21. Stereo Single-Ended Input Configuration, Gain = 6 dB

SSM2302

EXTERNAL GAIN SETTINGS = $20 \log[4/(1 + R/150k\Omega)]$



¹ INPUT CAPS ARE OPTIONAL IF INPUT DC COMMON-MODE VOLTAGE IS APPROXIMATELY $V_{DD}/2$.

Figure 22. Stereo Differential Input Configuration, User-Adjustable Gain

06051-036

EXTERNAL GAIN SETTINGS = $20 \log[4/(1 + R/150k\Omega)]$

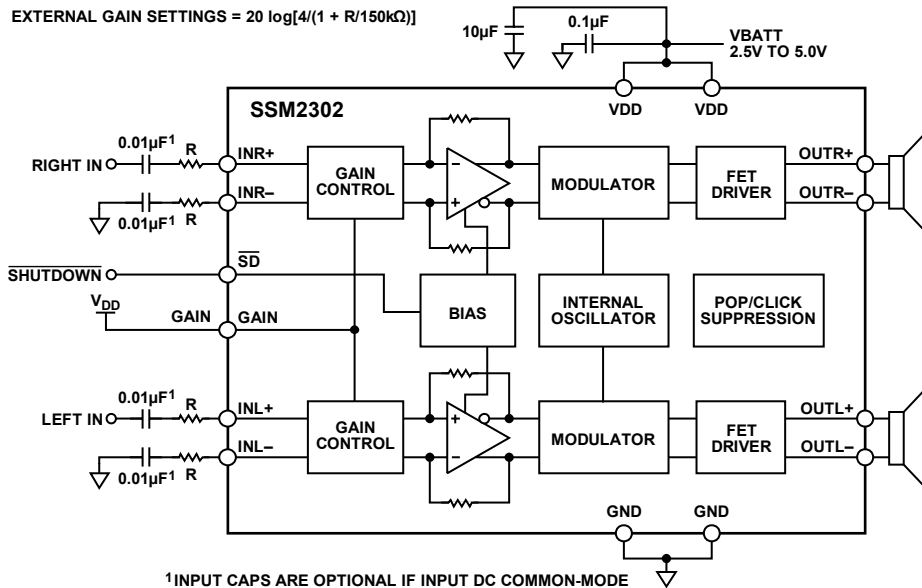

¹ INPUT CAPS ARE OPTIONAL IF INPUT DC COMMON-MODE VOLTAGE IS APPROXIMATELY $V_{DD}/2$.

Figure 23. Stereo Single-Ended Input Configuration, User-Adjustable Gain

06051-037

EXTERNAL GAIN SETTINGS = $20 \log[2/(1 + R/150k\Omega)]$

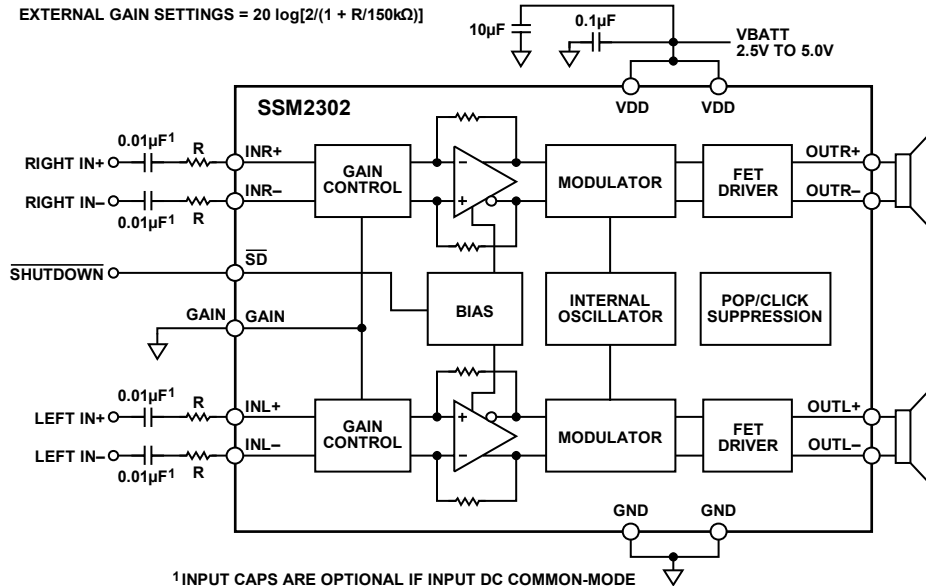

¹ INPUT CAPS ARE OPTIONAL IF INPUT DC COMMON-MODE VOLTAGE IS APPROXIMATELY $V_{DD}/2$.

Figure 24. Stereo Differential Input Configuration, User-Adjustable Gain

06051-038

EXTERNAL GAIN SETTINGS = $20 \log[2/(1 + R/150k\Omega)]$

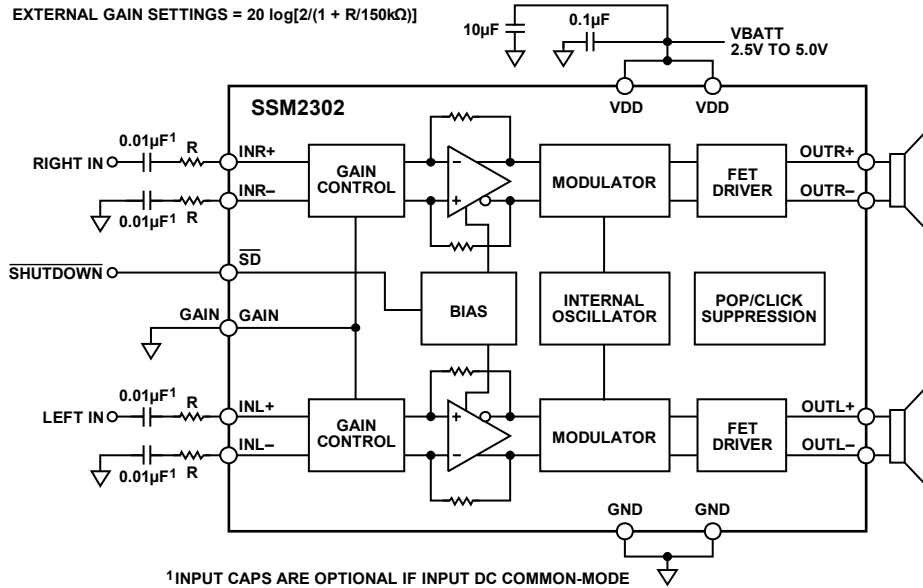

¹ INPUT CAPS ARE OPTIONAL IF INPUT DC COMMON-MODE VOLTAGE IS APPROXIMATELY $V_{DD}/2$.

Figure 25. Stereo Single-Ended Input Configuration, User-Adjustable Gain

06051-039

APPLICATION NOTES

OVERVIEW

The SSM2302 stereo Class-D audio amplifier features a filterless modulation scheme that greatly reduces the external components count, conserving board space and thus reducing systems cost. The SSM2302 does not require an output filter, but instead relies on the inherent inductance of the speaker coil and the natural filtering of the speaker and human ear to fully recover the audio component of the square-wave output. While most Class-D amplifiers use some variation of pulse-width modulation (PWM), the SSM2302 uses a Σ - Δ modulation to determine the switching pattern of the output devices. This provides a number of important benefits. Σ - Δ modulators do not produce a sharp peak with many harmonics in the AM frequency band, as pulse-width modulators often do. Σ - Δ modulation provides the benefits of reducing the amplitude of spectral components at high frequencies; that is, reducing EMI emission that might otherwise be radiated by speakers and long cable traces. The SSM2302 also offers protection circuits for overcurrent and temperature protection.

GAIN SELECTION

Pulling the GAIN pin high of the SSM2302 sets the gain of the speaker amplifier to 12 dB; pulling it low sets the gain of the speaker amplifier to 6 dB.

It is possible to adjust the SSM2302 gain by using external resistors at the input. To set a gain lower than 12 dB refer to Figure 22 for differential input configuration and Figure 23 for single-ended configuration. For external gain configuration from a fixed 12 dB gain, please use the following formula:

$$\text{External Gain Settings} = 20 \log[4/(1 + R/150 \text{ k}\Omega)]$$

To set a gain lower than 6 dB refer to Figure 24 for differential input configuration and Figure 25 for single-ended configuration. For external gain configuration from a fixed 6 dB gain, use the following formula:

$$\text{External Gain Settings} = 20 \log[2/(1 + R/150 \text{ k}\Omega)]$$

POP-AND-CLICK SUPPRESSION

Voltage transients at the output of audio amplifiers can occur when shutdown is activated or deactivated. Voltage transients as low as 10 mV can be heard as an audio pop in the speaker. Clicks and pops can also be classified as undesirable audible transients generated by the amplifier system, therefore as not coming from the system input signal. Such transients can be generated when the amplifier system changes its operating mode. For example, the following can be sources of audible transients: system power-up/power-down, mute/unmute, input source change, and sample rate change. The SSM2302 has a pop-and-click suppression architecture that reduces this output transients, resulting in noiseless activation and deactivation.

EMI NOISE

The SSM2302 uses a proprietary modulation and spread-spectrum technology to minimize EMI emissions from the device. Figure 26 shows SSM2302 EMI emission starting from 100 kHz to 30 MHz. Figure 27 shows SSM2302 EMI emission from 30 kHz to 2 GHz. These figures clearly describe the SSM2302 EMI behavior as being well below the FCC regulation values, starting from 100 kHz and passing beyond 1 GHz of frequency. Although the overall EMI noise floor is slightly higher, frequency spurs from the SSM2302 are greatly reduced.

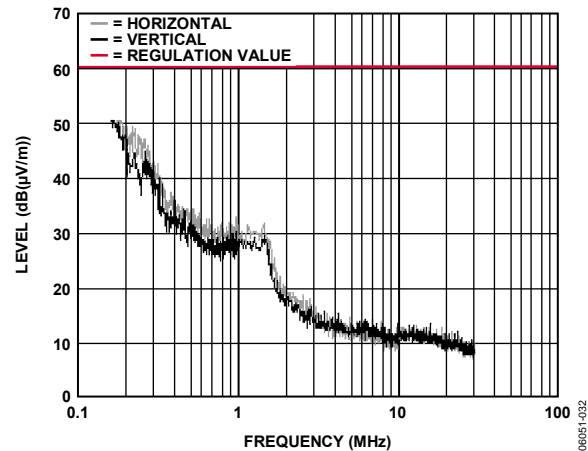

Figure 26. EMI Emissions from SSM2302

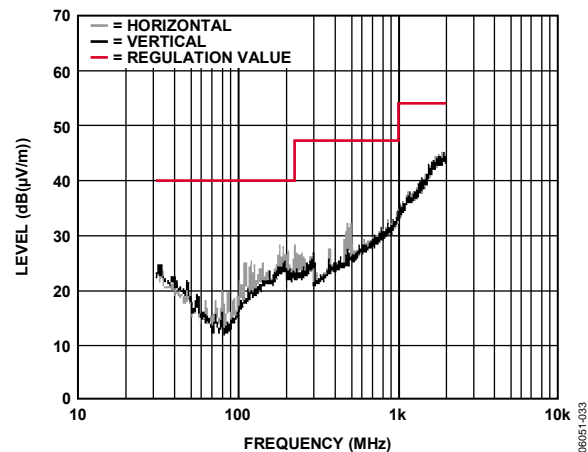

Figure 27. EMI Emissions from SSM2302

The measurements for Figure 26 and Figure 27 were taken with a 1 kHz input signal, producing 0.5 W output power into an 8 Ω load from a 3.6 V supply. Cable length was approximately 5 cm. The EMI was detected using a magnetic probe touching the 2” output trace to the load.

LAYOUT

As output power continues to increase, care needs to be taken to lay out PCB traces and wires properly between the amplifier, load, and power supply. A good practice is to use short, wide PCB tracks to decrease voltage drops and minimize inductance. Make track widths at least 200 mil for every inch of track length for lowest DCR, and use 1 oz or 2 oz of copper PCB traces to further reduce IR drops and inductance. A poor layout increases voltage drops, consequently affecting efficiency. Use large traces for the power supply inputs and amplifier outputs to minimize losses due to parasitic trace resistance. Proper grounding guidelines helps to improve audio performance, minimize crosstalk between channels, and prevent switching noise from coupling into the audio signal. To maintain high output swing and high peak output power, the PCB traces that connect the output pins to the load and supply pins should be as wide as possible to maintain the minimum trace resistances. It is also recommended to use a large-area ground plane for minimum impedances. Good PCB layouts also isolate critical analog paths from sources of high interference. High frequency circuits (analog and digital) should be separated from low frequency ones. Properly designed multilayer printed circuit boards can reduce EMI emission and increase immunity to RF field by a factor of 10 or more compared with double-sided boards. A multilayer board allows a complete layer to be used for ground plane, whereas the ground plane side of a double-side board is often disrupted with signal crossover. If the system has separate analog and digital ground and power planes, the analog ground plane should be underneath the analog power plane, and, similarly, the digital ground plane should be underneath the digital power plane. There should be no overlap between analog and digital ground planes nor analog and digital power planes.

INPUT CAPACITOR SELECTION

The SSM2302 will not require input coupling capacitors if the input signal is biased from 1.0 V to $V_{DD} - 1.0$ V. Input capacitors are required if the input signal is not biased within this recommended input dc common-mode voltage range, if high-pass filtering is needed (Figure 20), or if using a single-ended source (Figure 21). If high-pass filtering is needed at the input, the input capacitor along with the input resistor of the SSM2302 will form a high-pass filter whose corner frequency is determined by the following equation:

$$f_c = 1/(2\pi \times R_{IN} \times C_{IN})$$

Input capacitor can have very important effects on the circuit performance. Not using input capacitors degrades the output offset of the amplifier as well as the PSRR performance.

PROPER POWER SUPPLY DECOUPLING

To ensure high efficiency, low total harmonic distortion (THD), and high PSRR, proper power supply decoupling is necessary. Noise transients on the power supply lines are short-duration voltage spikes. Although the actual switching frequency can range from 10 kHz to 100 kHz, these spikes can contain frequency components that extend into the hundreds of megahertz. The power supply input needs to be decoupled with a good quality low ESL and low ESR capacitor—usually around 4.7 μ F. This capacitor bypasses low frequency noises to the ground plane. For high frequency transients noises, use a 0.1 μ F capacitor as close as possible to the VDD pin of the device. Placing the decoupling capacitor as close as possible to the SSM2302 helps maintain efficiency performance.

EVALUATION BOARD INFORMATION

INTRODUCTION

The SSM2302 audio power amplifier is a complete low power, Class-D, stereo audio amplifier capable of delivering 1.4 W/channel into 8 Ω load. In addition to the minimal parts required for the application circuit, measurement filters are provided on the evaluation board so that conventional audio measurements can be made without additional components.

This section provides an overview of Analog Devices SSM2302 evaluation board. It includes a brief description of the board as well as a list of the board specifications.

Table 5. SSM2302 Evaluation Board Specifications

| Parameter | Specification |
|---|----------------|
| Supply Voltage Range, V_{DD} | 2.5 V to 5.0 V |
| Power Supply Current Rating | 1.5 A |
| Continuous Output Power, P_o ($R_L = 8 \Omega$, $f = 1 \text{ kHz}$, 22 kHz BW) | 1.4 W |
| Minimum Load Impedance | 8 Ω |

OPERATION

Use the following steps when operating the SSM2302 evaluation board.

Power and Ground

1. Set the power supply voltage between 2.5 V and 5.0 V. When connecting the power supply to the SSM2302 evaluation board, make sure to attach the ground connection to the GND header pin first and then connect the positive supply to the VDD header pin.

Inputs and Outputs

1. Ensure that the audio source is set to the minimum level.
2. Connect the audio source to Inputs INL \pm and INR \pm .
3. Connect the speakers to Outputs OUTL \pm and OTR \pm .

Gain Control

The gain select header controls the gain setting of the SSM2302.

1. Select jumper to LG for 6 dB gain.
2. Select jumper to HG for 12 dB gain.

External Gain Settings

It is possible to adjust the SSM2302 gain using external resistors at the input. To set a gain lower than 12 dB refer to Figure 22 and Figure 23 on the product data sheet for proper circuit configuration. For external gain configuration from a fixed 12 dB gain, use the following formula:

$$\text{External Gain Settings} = 20 \log[4/(1 + R/150 \text{ k}\Omega)]$$

To set a gain lower than 6 dB refer to Figure 24 and Figure 25 on the product data sheet for proper circuit configuration. For external gain configuration from a fixed 6 dB gain, use the following formula:

$$\text{External Gain Settings} = 20 \log[2/(1 + R/150 \text{ k}\Omega)]$$

Shutdown Control

The shutdown select header controls the shutdown function of the SSM2302. The shutdown pin on the SSM2302 is active low, meaning that a low voltage (GND) on this pin places the SSM2302 into shutdown mode.

1. Select jumper to 1-2 position. Shutdown pulled to V_{DD} .
2. Select jumper to 2-3 position. Shutdown pulled to GND.

Input Configurations

1. For differential input configuration with input capacitors do not place a jumper on JP8, JP9, JP10, and JP11.
2. For differential input configuration without input capacitors place a jumper on JP8, JP9, JP10, and JP11.

SSM2302 APPLICATION BOARD SCHEMATIC

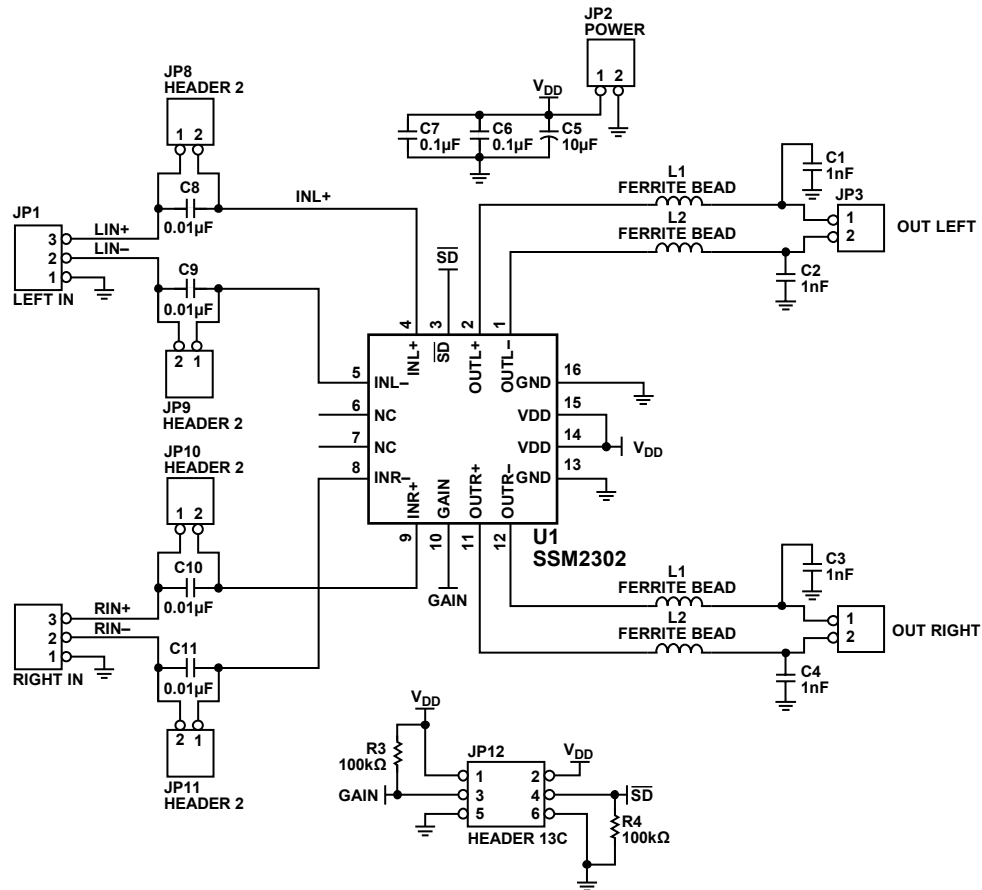

Figure 28. SSM2302 Application Board Schematic

06051-034

SSM2302

SSM2302 STEREO CLASS-D AMPLIFIER EVALUATION MODULE COMPONENT LIST

Table 6.

| Reference | Description | Footprint | Quantity | Manufacturer/Part Number |
|------------------|--------------------------|------------------------|----------|---|
| C8, C9, C10, C11 | Capacitors, 0.01 μ F | 0402 | 4 | Murata Manufacturing Co., Ltd./GRM15 |
| C6, C7 | Capacitor, 0.1 μ F | 0603 | 2 | Murata Manufacturing Co., Ltd./GRM18 |
| C5 | Capacitor, 10 μ F | 0805 | 1 | Murata Manufacturing Co., Ltd./GRM21 |
| C1, C2, C3, C4 | Capacitor, 1 nF | 0402 | 4 | Murata Manufacturing Co., Ltd./GRM15 |
| R3, R4 | Resistor, 100 k Ω | 0603 | 2 | Vishay/CRCW06031003F |
| L1, L2, L3, L4 | Ferrite bead | 0402 | 4 | Murata Manufacturing Co., Ltd./BLM15EG121 |
| U1 | IC, SSM2302 | 3.0 mm \times 3.0 mm | 1 | SSM2302CSPZ |
| EVAL BOARD | PCB evaluation board | | 1 | |

SSM2302 APPLICATION BOARD LAYOUT

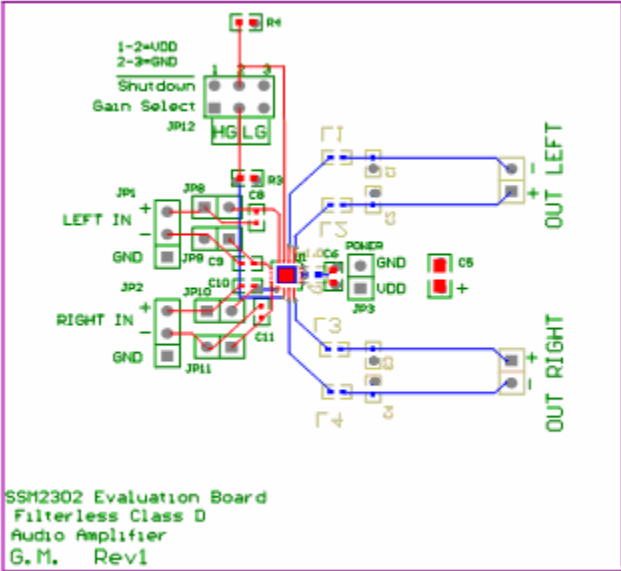
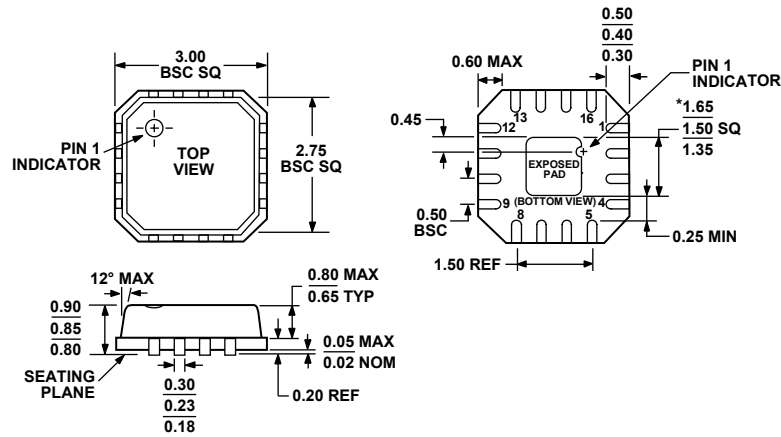

Figure 29. SSM2302 Application Board Layout

06051-035

SSM2302

OUTLINE DIMENSIONS



*COMPLIANT TO JEDEC STANDARDS MO-220-VEED-2 EXCEPT FOR EXPOSED PAD DIMENSION.

Figure 30. 16-Lead Lead Frame Chip Scale Package [LFCSP_VQ]
 3 mm × 3 mm Body, Very Thin Quad
 (CP-16-3)
 Dimensions shown in millimeters

ORDERING GUIDE

| Model | Temperature Range | Package Description | Package Option | Branding |
|-------------------------------|-------------------|--|----------------|----------|
| SSM2302CPZ-R2 ¹ | -40°C to +85°C | 16-Lead Lead Frame Chip Scale Package [LFCSP_VQ] | CP-16-3 | A15 |
| SSM2302CPZ-REEL ¹ | -40°C to +85°C | 16-Lead Lead Frame Chip Scale Package [LFCSP_VQ] | CP-16-3 | A15 |
| SSM2302CPZ-REEL7 ¹ | -40°C to +85°C | 16-Lead Lead Frame Chip Scale Package [LFCSP_VQ] | CP-16-3 | A15 |

¹ Z = Pb-free part.

NOTES

SSM2302

NOTES